



# INDIGENUS

2025 / 26

Planters for Indoors & Outdoors



## Contents

|    |  |
|----|--|
| 5  | Founder's Note   |
| 7  | Sustainability   |
| 8  | Our Process  |
| 10 | Petra, designed by Fernando Mastrangelo                  |
| 18 | Pebble, designed by Yabu Pushelberg                      |
| 26 | Aarde, designed by Sebastian Herkner                     |
| 32 | Terra, designed by Laurie Wiid van Heerden               |
| 38 | Bhaca, designed by Andile Dyalvane                       |
| 44 | Tuber, designed by Haldane Martin                        |
| 50 | Soma, designed by Laurie Wiid van Heerden                |
| 58 | Steen, designed by Stefan Antoni and Greg Truen of SAOTA |
| 64 | Projects   |
| 66 | Specifications   |
| 80 | Contact Details  |



The heart and soul of our business is our team of artisans. The factory is situated within a nature conservation area in Muizenberg, Cape Town. It is built around a large central wetland and is home to remarkable fauna and flora. We have a family of otters that watch us curiously from the banks.

## From the Founder



It is my pleasure to welcome you to the world of Indigenus.

Planters are so often seen as an afterthought or purely as functional. I wanted to change that. Our mission is to elevate the design status of planters, reimagine them as objects of art, and bring beauty to the spaces we live in.

Each of our collections began with a considered decision to find the right designer to create what we envisioned. We've been fortunate to have some of the world's best designers bring those visions to life. Matching the quality of the planters with the quality of the designs has been a challenge. However, with our own factory since 2018, we believe we are now succeeding.

To me, true luxury is about objects that are beautiful, sustainable, durable and manufactured with meticulous detail. But to be exceptional, something more is needed that is felt and uplifts us and the spaces we inhabit. This is what we try to achieve.

Thank you for letting us be part of your space and your story. It's an honour to share this vision, expressed in the pages that follow, with you...

Peter van der Post



## Sustainability

We believe that purchasing fewer, higher-quality products is vital to our company's role in fostering a sustainable future. One reason we manufacture all our planters in-house is to enable continuous quality improvement and to create planters that are built to last a lifetime, not just a season. For us, this move away from trends or 'fast fashion' embodies the idea of progressing in the most sustainable manner.

Our planters are made from Glass Reinforced Concrete (GRC). The GRC manufacturing process neither utilises nor releases volatile organic compounds (VOCS). Additionally, this GRC is twenty times stronger and more durable than standard concrete. We are dedicated to reducing our carbon footprint by carefully selecting sustainable raw materials and methods. For example, nearly fifty per cent of the GRC formulation consists of naturally occurring earth oxides.

Our wooden planters are crafted from Iroko (African teak), a hardwood certified by the Forest Stewardship Council (FSC) and sourced from sustainably harvested suppliers. This dense, durable timber is rich in natural resins and oils. Iroko has a high oil content and is exceptionally durable, as well as resistant to both rot and insect infestations.

Additionally, all planters are transported in recyclable corrugated boxes with minimal packaging, and all liners are produced from recyclable polyethylene.

We are dedicated to regularly reviewing and adopting more sustainable practices as we grow.



#### Made in South Africa by Artisans and Craftsmen

The production of Indigenus planters follows a slow, artisanal process. Some planters, made from a combination of wood and stone, can take up to 20 man-hours to complete. Despite using top-quality tools and the most durable natural materials, our approach to crafting lightweight, natural, and earthy products designed to last a lifetime requires significant time, skill, and craftsmanship.

Opposite Page: We keep our top sellers in stock for quick turnaround time

Top Right: All planters are fitted with soft touch feet and can be placed on delicate flooring/carpets

Middle Right: All our planters are brushed and packed up by hand

Bottom Right: Bhaca, designed by Andile Dyalvane, being demoulded

#### Materials

We utilise GRC (glass reinforced concrete) using a two-skin technique that features an outer face coat made from locally sourced aggregates, sands, oxides, and cements from Africa, all of which are meticulously layered and finished by hand.

After moulding, these pieces require skilled finishing to accentuate the natural imperfections and details of the stone, whilst removing the join lines for a durable, earthy finish that aligns with our ethos. Beneath the outer layer lies an incredibly strong back coat composed of concrete, strengtheners, and alkaline glass fibres. This formulation makes the material over 20 times stronger than standard concrete, which, in conjunction with our liner system, enables us to keep our large planters relatively lightweight, yet incredibly durable.

Our FSC-certified African Iroko/Teak, which has been used to make boats for centuries, uses thick hand-cut sections and is turned on a lathe on completion. Each segment of wood is bound to the next by four stainless steel screws, ensuring these pieces can last a lifetime.



# Petra

by Fernando Mastrangelo



Petra, designed by Fernando Mastrangelo, Medium in Nutmeg



Petra is the newest range of planters by Indigenus, designed by Fernando Mastrangelo. The Petra planter merges the two key elements of Fernando's practice: the drum or cylinder shape and the Petra (meaning rock or stone), or rock-like formations. The result is a stunning planter that highlights the contrast between geometric precision and organic textures, beautifully emphasising their differences.

The Petra has proven to be the most complex design to bring to life. It is eclectic, pushing the boundaries of what Indigenus has previously created. The result is a far more demanding aesthetic and, ultimately, a disruptive design for a planter.

Petra is created for interiors, exteriors, hospitality, residential, and corporate environments. It works well as standalone statement pieces and makes a bold impact when grouped.

Left: Petra Medium in Brown

Above: Petra Small, Medium and Tall in Black

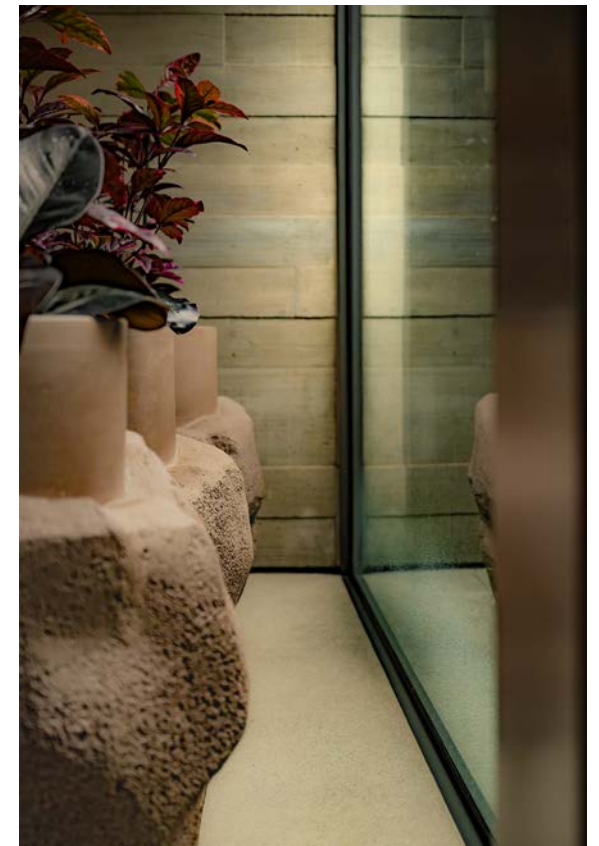

“This collection offers a fresh perspective on planters, primarily because we’re moulding directly from an original cast piece using coal, silica, sand, and other crushed materials while also incorporating sculptural elements rarely seen in this area of design. To me, design is about creating sculptures that people can live with and use, and this collection pushes that concept forward in an exciting new direction.”

Fernando Mastrangelo

Petra Medium in Mushroom



Petra Medium in Black and Small in Brown



# Pebble

by Yabu Pushelberg



Pebble, designed by Yabu Pushelberg, Medium and Midi in Mushroom and Tall in Nutmeg



Left: Pebble Tall, Small and Midi in Mushroom.

Above: Pebble Troughs in Oatmeal.

The Pebble planter is a collaborative creation with international design studio Yabu Pushelberg. Known for their calm, minimalist yet soft and warm high-end interiors, Yabu Pushelberg approached Indigenus after seeing the planters at Avenue Road in Toronto. They wanted to collaborate on a planter that would suit their projects, as they couldn't find one that met their preferences.

This led to the Pebble range, characterised by its soft, organic shape, suitable for almost any style and setting.

The Pebble features an asymmetrical design with a beautiful play on negative space. Inspired by nature, the partnership between Yabu Pushelberg and Indigenus aimed to honour this muse by celebrating her amorphous forms, as if shaped by water, like pebbles. These soft forms were then translated into a family of planters.

Designed to stand alone or together, the Pebble planters have been crafted to support larger plants and trees than our other ranges.

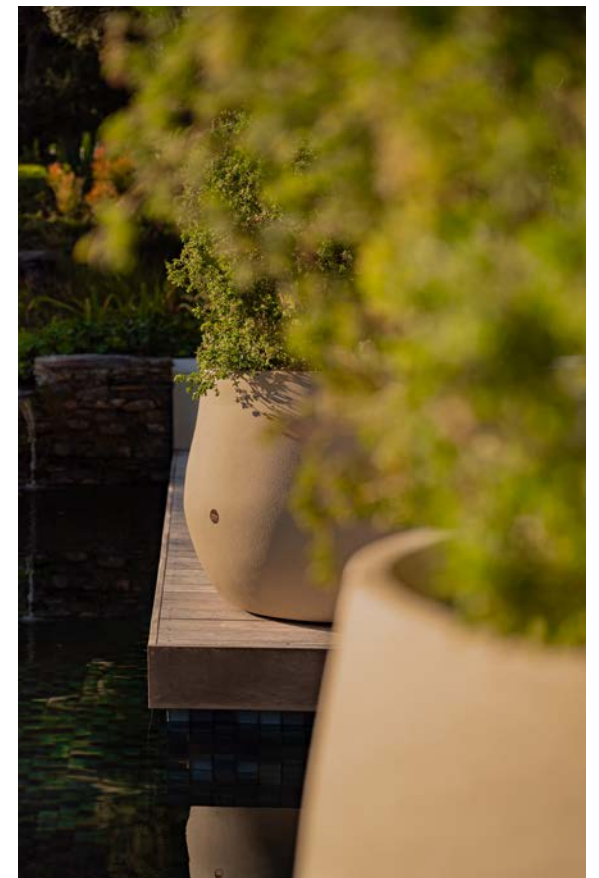
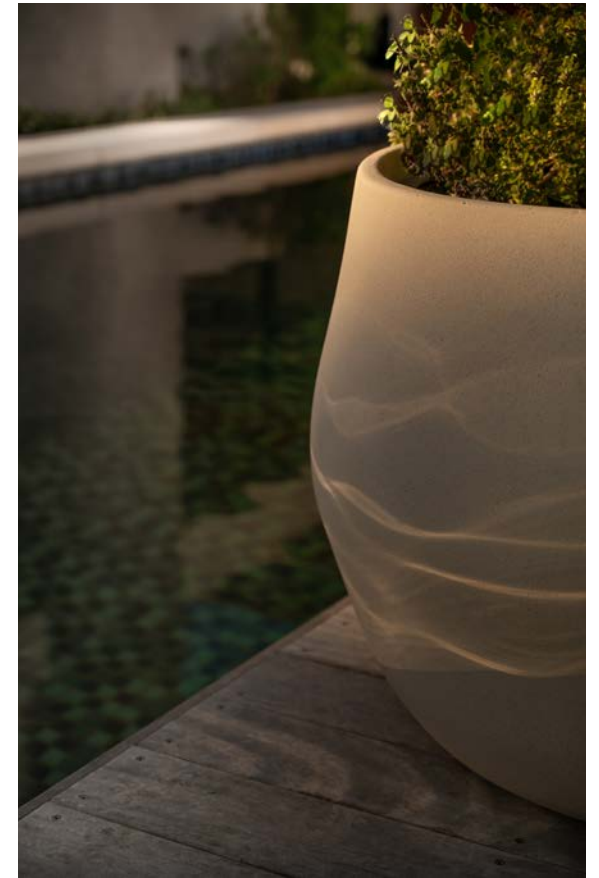

“Indigenus is a positive, generous, and engaging partner who shares the belief that quality design can positively shape our future. They are a collective of hard-working, open-minded craftsmen which is seen through their products and felt through the process of collaboration. We are honored to be introducing our inaugural collection and to continue to produce thoughtful work together.”

Yabu Pushelberg

Pebble Small in White



Right: Pebble Tall and Medium in Sandstone and Large in Black.

Above: Pebble Mama, Tall, Medium and Small in Sandstone

The Pebble Mama was recently added to the Pebble family to complete the range. This large scale statement planter is best suited to entrances, public spaces, large foyers and courtyards.

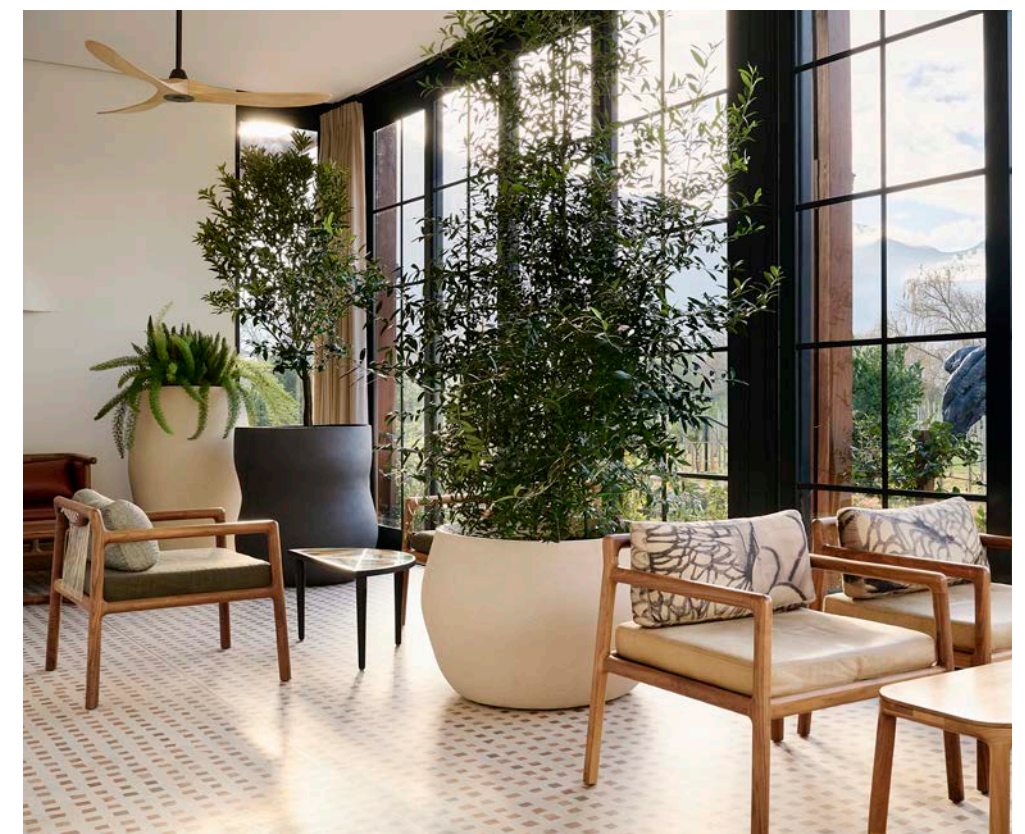



Aarde, designed by Sebastian Herkner, Tall in Sandstone



Opposite Page: Aarde Slim Trough in Grey  
 Right: Aarde Square in Grey  
 Above: Aarde Slim Troughs in Terracotta and XS Square  
 and XS Tall in Sandstone

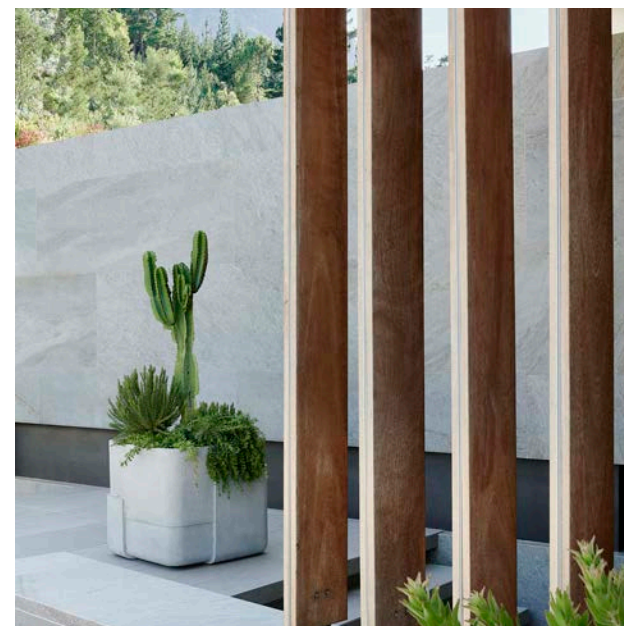

The global context served as a key link between Sebastian Herkner and Peter van der Post. With an expanding international distributor network, Indigenus emphasises the importance of designing products that are effective on a global scale, a goal Sebastian actively pursues.

“We are looking for companions for life, not a trend, and we want great designs with long lasting function and quality. This is sustainability.”

Sebastian Herkner



Aarde Tall XS in Terracotta, Aarde Tall, Square and Trough in Brown



Aarde Tall and XS in Brown and Square XS and Tall XS in Sandstone

Following his honeymoon in South Africa, German designer, Sebastian Herkner, was inspired by the landscape he observed.

Aarde, meaning earth, is a representation of this. The different layers, at various depths, mimic what he saw in the topography of the land and accentuate the interplay of light and minerality that he sought to capture.

The earthy colours introduced concurrently with this range are very much part of the story Sebastian wanted to communicate.

# Terra

by Laurie Wiid van Heerden



Terra Trough, designed by Laurie Wiid van Heerden, in Grey

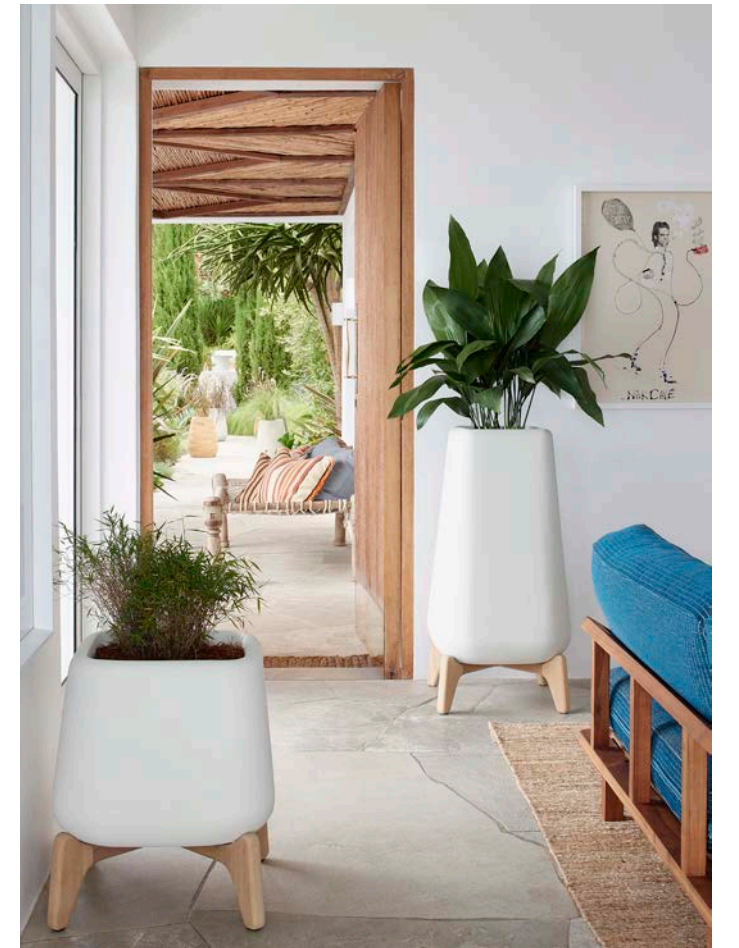

Left: Terra Tall and Square in Grey

Above: Terra Tall XS and Square XS in White

Terra, meaning earth in Latin, brings substance and grounding to the mid-century modern tradition of using planters on stands.

The substantial wooden bases are sculpted around the planter, creating a stable, earthy interpretation that elevates the Terra, giving the planters a furniture-like appearance.

“The Terra design lifts the planters off the ground, elevating them while adding elegance to the otherwise bold, curved, and bulky glass-reinforced concrete planter component. Our signature curved details soften the design and create a harmonious balance between the delicate wooden legs and the solid concrete form, offering both structure and fluidity”

Laurie Wiid van Heerden



Terra Tall and Tall XS and Square and Square XS in Mushroom

# Bhaca

by Andile Dyalvane



Bhaca, designed by Andile Dyalvane, Medium in Terracotta and Small in Nutmeg

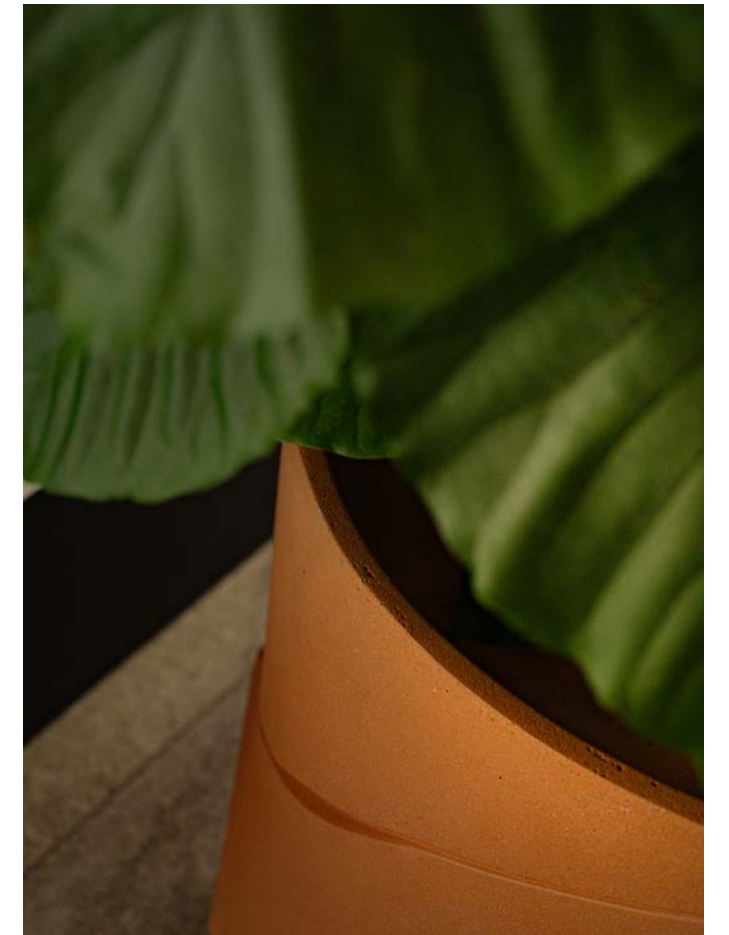

Bhaca Large in Brown, Medium in Nutmeg and Small in Terracotta

The Bhaca is a personal and original range of stone planters that reflect ceramicist Andile Dyalvane's connection to his Xhosa roots while celebrating his mastery of his chosen elemental material – clay. Bhaca, meaning scarification, is a traditional Xhosa method of intricately cutting skin (usually on the cheeks) to mark initiation, clan identification, or healing.

Andile's desire is to preserve and share his cultural roots of this ancient tradition by cutting into clay and pushing open the cuts where they intersect as if to open the flesh.

The Bhaca was electronically scanned and scaled up from smaller clay vessels sculpted by Andile, to form bigger impactful planters made from glass re-inforced concrete, that share this story with the world.



Left: Bhaca XS in White  
Above: Bhaca Medium in Mushroom

“UkuBhaca (Uqaphula) is not only a word derived from the amaBhaca peoples isiXhosa dialect, but is the traditional practice of scarification by both Nguni lineages who reside in Southern Africa.

This practice of scarification aids healing protection, transmutation towards an ancestral settlement and beautification that serves as clan or family symbols of belonging as well as status identification. It is regarded as a rite of passage into family and communal life.”

Andile Dyalvane

# Tuber

by Haldane Martin



Tuber, designed by Haldane Martin, Tall and Medium in Black, Medium in Wood and Small in Grey



Tuber Tall and XS in Mushroom, Medium in Grey and Small and XS in Sandstone

Haldane Martin's Tuber, as the name suggests, is inspired by the tubular shape of many roots and bulbs that lie just beneath the surface of the soil. It is almost as if the planter brings this subterranean shape out to represent the life support system of the plant for all to see - life springing forth and nourished from a tubular root structure.



Above: Tuber Tall in Natural Wood and Teracotta, Medium in Sandstone and Small in Brown  
Right: Tall, Medium and Small Tubers in Natural Wood

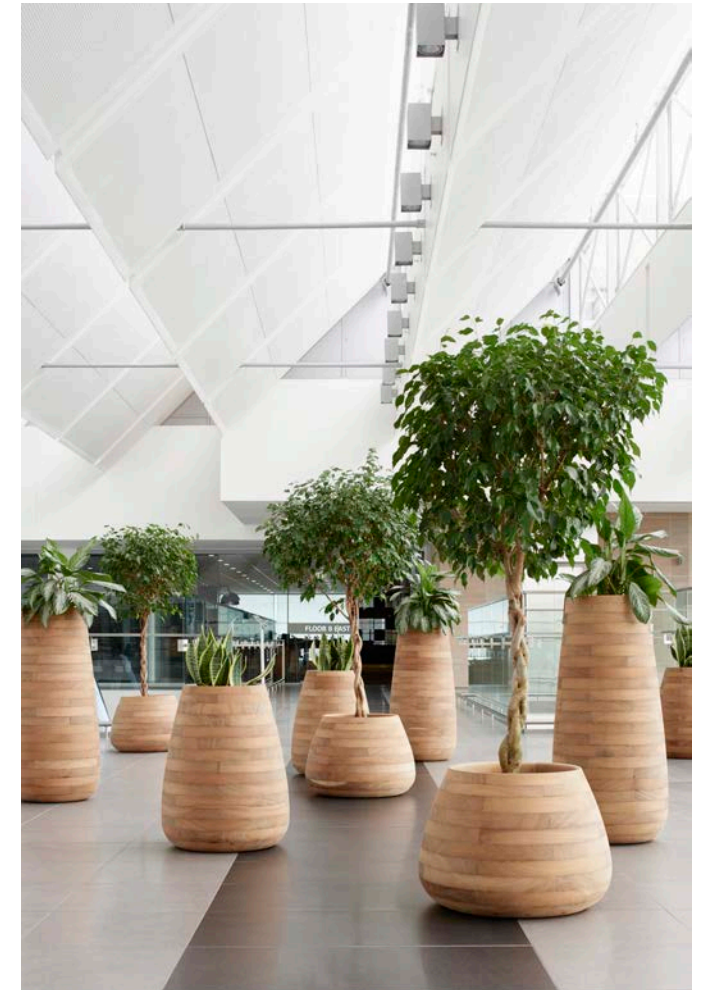

“Designing meaningful objects helps us understand ourselves and creates a sense of belonging to time and space.”

Haldane Martin



Soma by Laurie Wiid van Heerden

Soma, designed by Laurie Wiid van Heerden, Tall in Nutmeg, Medium in Mushroom



Soma Tall in Brown, Medium in Nutmeg and Small in Mushroom

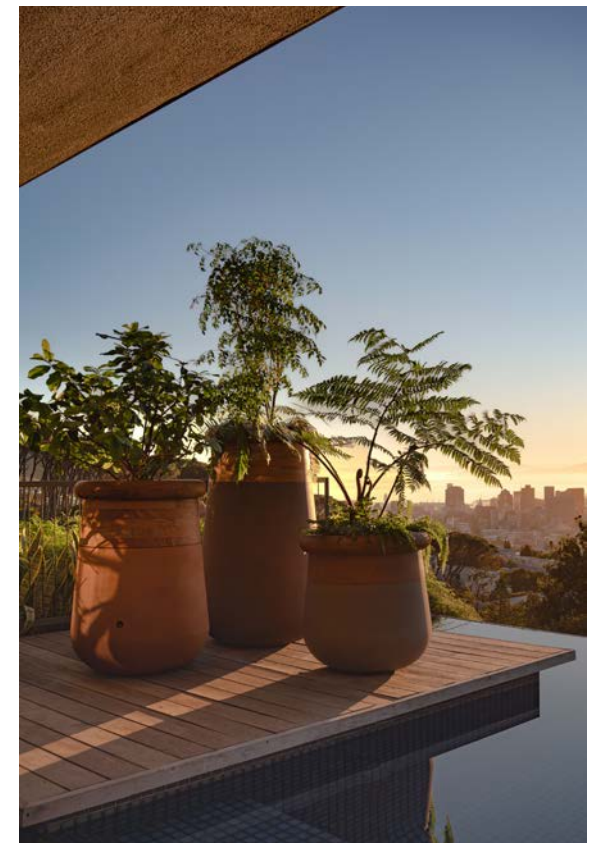
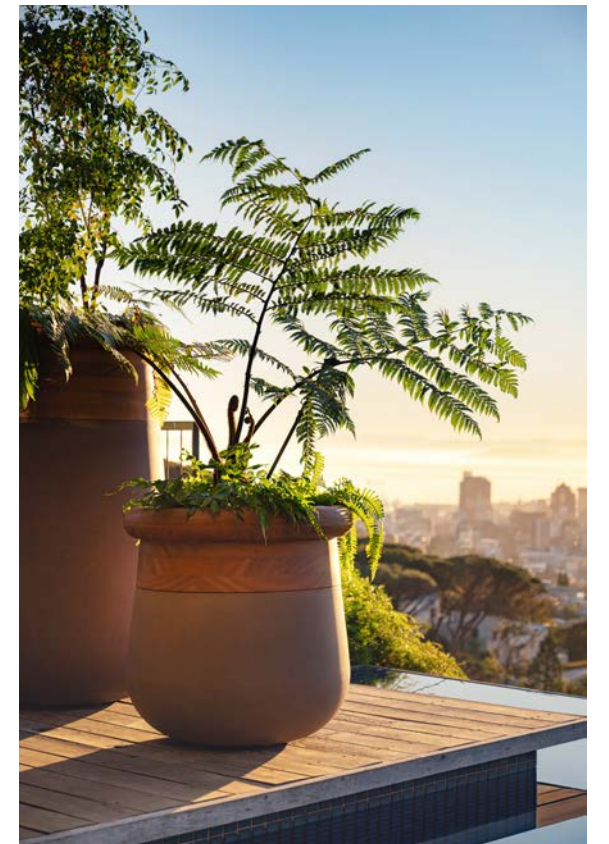

Soma is the Greek word for “body” and Laurie Wiid van Heerden’s design of the Soma is inspired by the body of a tree. The trunk like shape carries leaves towards the sky raising them upwards and above other plants.

The Soma planters, some which are substantial in size, do the same and lift beautiful plants up via a curvaceous tree trunk likeness which includes timber as part of that body of the tree.

Soma Tall in Grey





Above: Soma, Medium and Small in Mushroom  
Right: Soma Slim in Terracotta

"The word 'Soma' speaks to the body - the form, structure, and essence of living organisms. With the Soma Planter collection, I was drawn to the idea of grounding the design in the natural world, drawing inspiration from the graceful solidity of tree trunks. The planters feature soft, organic curves and gentle transitions, reflecting a contemporary interpretation of nature's architecture. As someone who has long been captivated by succulents and cacti, designing a collection that both frames and enhances the quiet beauty of plants was an incredibly rewarding process."

Laurie Wiid van Heerden





Steen by Stefan Antoni and Greg Truen of SAOTA

Steen, designed by SAOTA, Large in Brown, Medium in Nutmeg, Terracotta and Mushroom and Small in Sandstone and Nutmeg

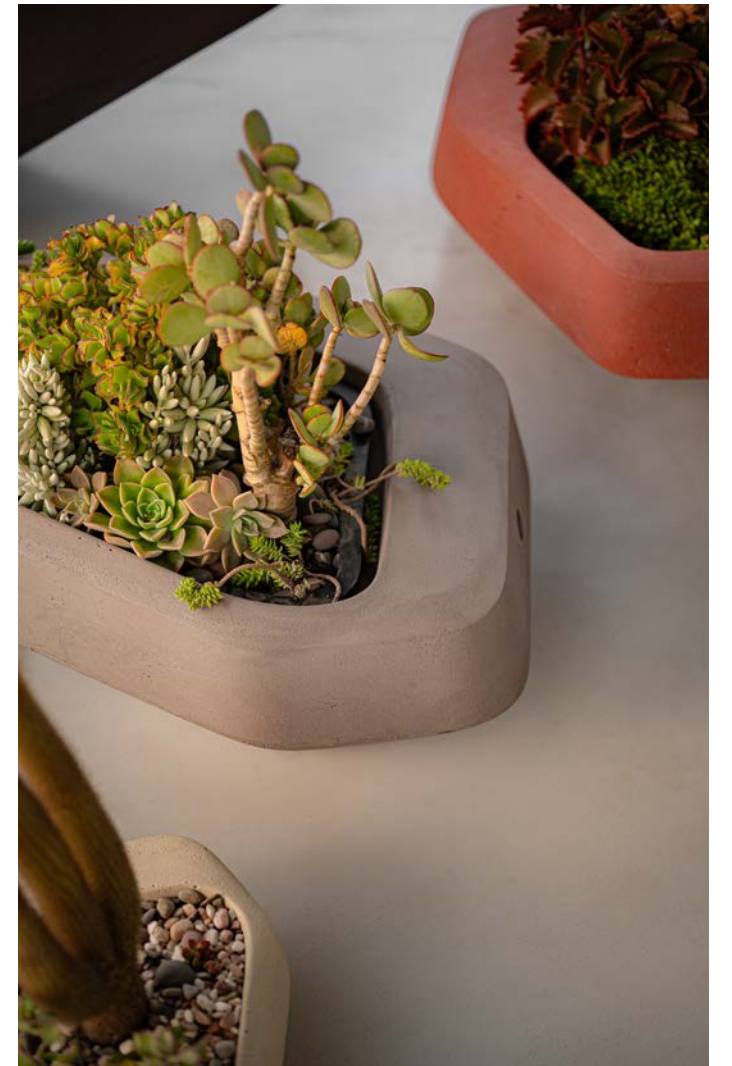

Stefan Antoni and Greg Truen of SAOTA drew inspiration from the geography of Cape Town, where boulders are scattered along the coastal cliffs. The landscape is dramatic, featuring the rare and renowned flora of the Cape Floral Kingdom, mixed with jutting rock formations.

The Afrikaans word for rock or stone is "steen," which inspired the low, stone-like shapes of the planters. The Steen planters are an architectural interpretation of these rocks.



“They are inspired by the kind of boulders you find in Cape Town: in places like Clifton and Llandudno, massive granite rocks – whether standing singularly on the mountain slope or in groups on the beach – create intriguing and alluring shapes and structures. So the design is an interpretation of forms found in nature, but with a modernist inflection. We wanted them to be dynamic and seem perched, as if on the edge of a cliff. Perhaps if Pierneef were to make a boulder he would land up somewhere close to where we did.”

Stefan Antoni and Greg Truen of SAOTA

# Specifications



## PETRA

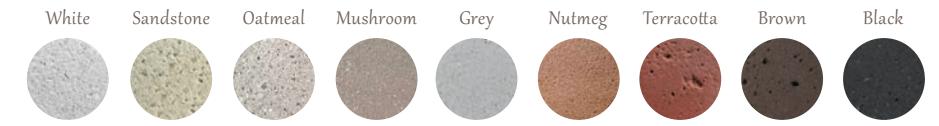

Tall | PET10S

All Stone  
weight: 100kg (220lb)  
inch: 38.2" x 33.5"

53cm Liner



Medium | PET07S

All Stone  
weight: 70kg (154lb)  
inch: 27.4" x 28.9"

40cm Liner



Small | PET06S

All Stone  
weight: 65kg (143lb)  
inch: 23.9" x 30.4"

30cm Liner

## LINERS

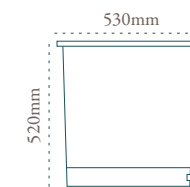

53 CM

round  
soil: 21 gal | 80l  
water: 1.3 gal | 5l  
20.4" x 20.8"

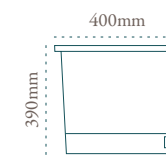

40 CM

round  
soil: 7.1 gal | 27l  
water: 1.6 gal | 6l  
15.3" x 15.7"

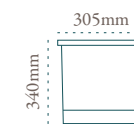

30 CM

round  
soil: 3.6 gal | 14l  
water: 0.8 gal | 3l  
13.8" x 12"

PEBBLE

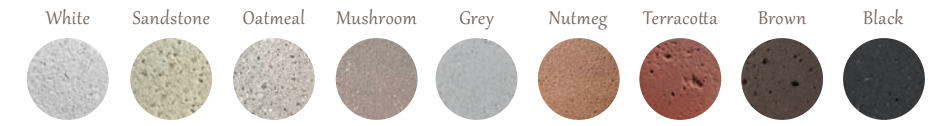

Mama | PEB15S

All Stone  
weight: 160kg (352lb)  
inch: 59" x 44.8"

60cm Liner

Tall | PEB12S

All Stone  
weight: 86kg (190lb)  
inch: 47.2" x 29.3"

53cm Liner

Medium | PEB09S

All Stone  
weight: 84kg (185lb)  
inch: 33.8" x 33.3"

70cm Liner

Midi | PEB07S

All Stone  
weight: 45kg (99lb)  
inch: 23.6" x 24.0"

40cm Liner

Small | PEB06S

All Stone  
weight: 65kg (143lb)  
inch: 23.6" x 33.5"

70cm Liner

Trough 2 | PEB08S

All Stone  
weight: 77kg (169lb)  
inch: 31.1" x 40.1"

1 x 40cm Liner, 1 x 30cm Liner

Trough 3 | PEB068S

All Stone  
weight: 75kg (165lb)  
inch: 26.7" x 41.3"

3 x 30cm Liner

XS | PEB05S

All Stone  
weight: 25kg (55lb)  
inch: 19.3" x 15.7"

30cm Liner

LINERS

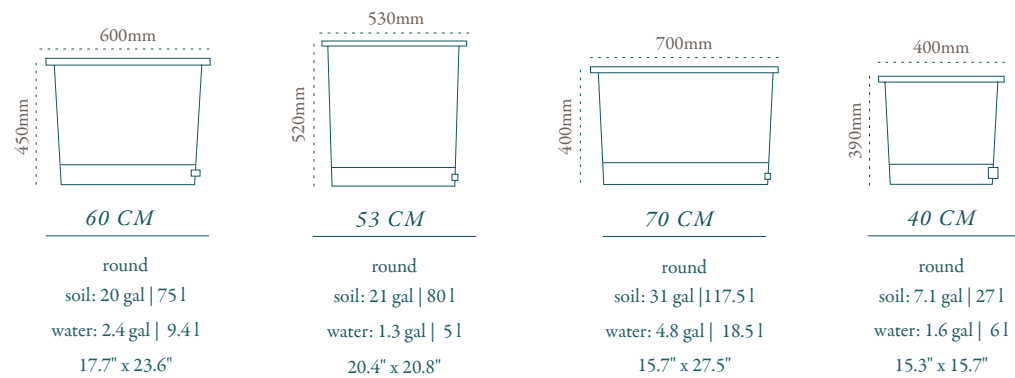

LINERS

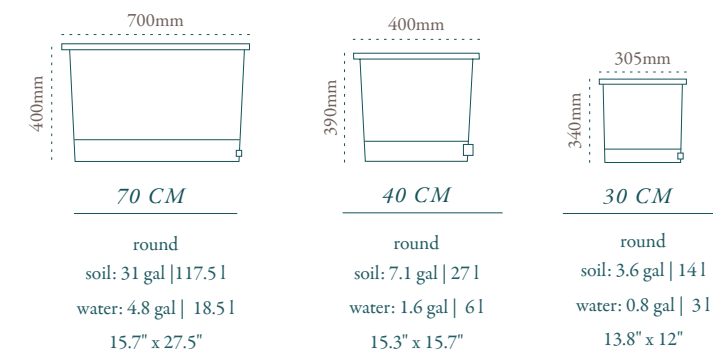

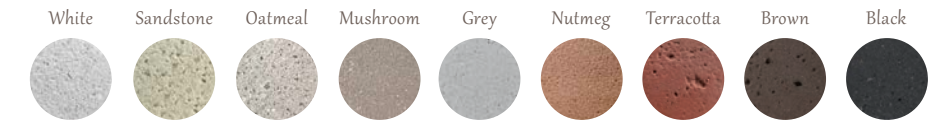

Tall | AAR10S

All Stone  
weight: 130kg (287lb)  
inch: 42.5" x 29.5"

60cm Liner



Square | AAR06S

All Stone  
weight: 95kg (209lb)  
inch: 27.1" x 29.5"

60cm Liner



Trough | AAR07S

All Stone  
weight: 125kg (276lb)  
inch: 55.1" x 22" x 26.7"

4 x 30cm Liner



Tall XS | AAR08S

All Stone  
weight: 50kg (110lb)  
inch: 31.8" x 16.9"

30cm Liner



Slim Trough | AAR088S

All Stone  
weight: 90kg (198lb)  
inch: 41.1" x 16.9" x 31.8"

3 x 30cm Liner



Square XS | AAR04S

All Stone  
weight: 30kg (66lb)  
inch: 16.9" x 16.9"

30 cm Liner

LINERS

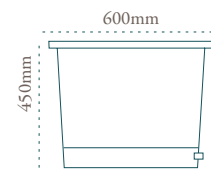

60 CM

round  
soil: 20 gal | 75 l  
water: 2.4 gal | 9.1 l  
17.7" x 23.6"

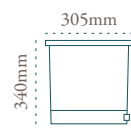

30 CM

round  
soil: 3.6 gal | 14 l  
water: 0.8 gal | 3 l  
13.8" x 12"

LINERS

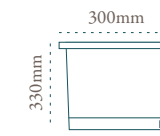

30 CM

square  
soil: 5.3 gal | 20 l  
water: 0.9 gal | 3.5 l  
12.9" x 11.8"

TERRA



Tall | TER13W

Stone with Wood  
weight: 85kg (187lb)  
inch: 51.1" x 23.7"

30cm Liner



Square | TER07W

Stone with Wood  
weight: 65kg (143lb)  
inch: 27.5" x 23.7"

40cm Liner



Square XS | TER05W

Stone with Wood  
weight: 32kg (71lb)  
inch: 20.6" x 17.7"

23cm Liner



Tall XS | TER09W

Stone with Wood  
weight: 44kg (97lb)  
inch: 36.2" x 17.7"

23cm Liner



Trough | TER08W

Stone with Wood  
weight: 90kg (198lb)  
inch: 48.1" x 17.3" x 33.5"

3 x 30cm Liner



LINERS

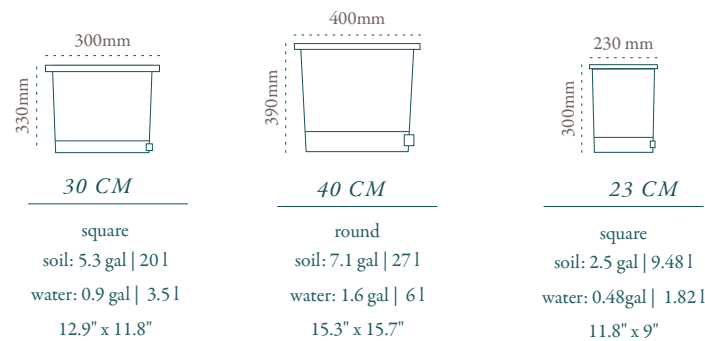

LINERS

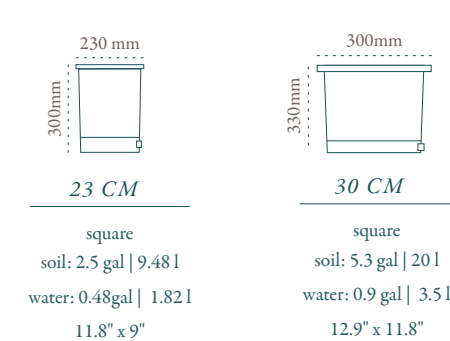

# BHACA

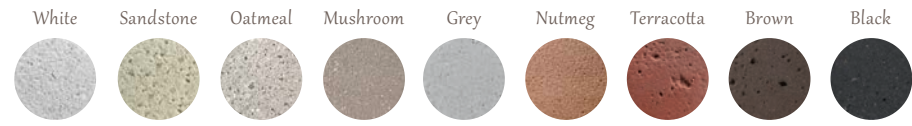

# TUBER

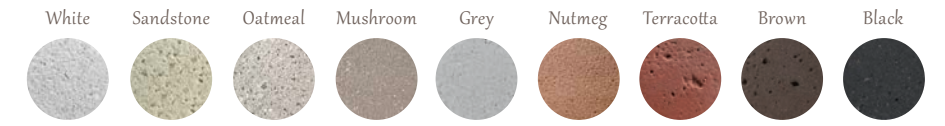

|   |   |  |  |
|---|---|--|--|
| <p><b>Tall   BHA11S</b></p> <p>All Stone<br/>weight: 85kg (187lb)<br/>inch: 44.8" x 29.2"</p> <p>40cm Liner</p> | <p><b>Medium   BHA09S</b></p> <p>All Stone<br/>weight: 75kg (165lb)<br/>inch: 37.5" x 30.6"</p> <p>40cm Liner</p> | <p><b>Small   BHA06S</b></p> <p>All Stone<br/>weight: 65kg (143lb)<br/>inch: 26.6" x 34.3"</p> <p>40cm Liner</p> | <p><b>XS   BHA05S</b></p> <p>All Stone<br/>weight: 25kg (55lb)<br/>inch: 22.2" x 17.7"</p> <p>23cm Liner</p> |
|---|---|--|--|



|  |  |   |  |
|--|--|---|--|
| <p><b>Tall   TUB10W/S</b></p> <p>Wood or Stone<br/>weight: W 36kg   S 55kg<br/>inch: 42.9" x 18.8"</p> <p>30cm Liner</p> | <p><b>Medium   TUB07W/S</b></p> <p>Wood or Stone<br/>weight: W 28kg   S 45kg<br/>inch: 27.9" x 22.4"</p> <p>30cm Liner</p> | <p><b>Small   TUB04W/S</b></p> <p>Wood or Stone<br/>weight: W 27kg   S 45kg<br/>inch: 18.7" x 26.2"</p> <p>40cm Liner</p> | <p><b>XS   TUB05W/S</b></p> <p>Wood or Stone<br/>weight: W 15kg   S 25kg<br/>inch: 22.1" x 11.6"</p> <p>23cm Liner</p> |
|--|--|---|--|

## LINERS

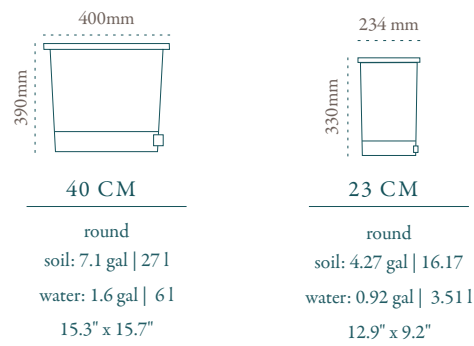

## LINERS

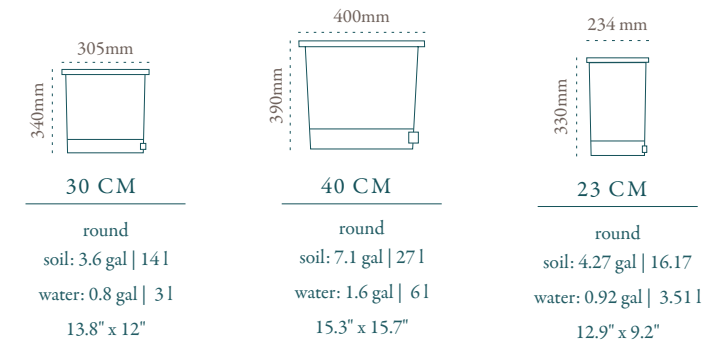



Tall | SOM13W

Stone with Wood  
weight: 100kg (242lb)  
inch: 51.1" x 31.1"

53cm Liner

Medium | SOM10W

Stone with Wood  
weight: 75kg (165lb)  
inch: 39.3" x 28.8"

53cm Liner

Small | SOM07W

Stone with Wood  
weight: 55kg (122lb)  
inch: 27.6" x 27.5"

53cm Liner

Slim | SOM12W

Stone with Wood  
weight: 65kg (143lb)  
inch: 47.2" x 21.9"

30cm Liner

Slim XS | SOM09W

Stone with Wood  
weight: 42kg (93lb)  
inch: 35" x 16.2"

23cm Liner

LINERS

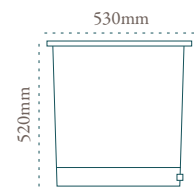

53 CM

round  
soil: 21 gal | 80 l  
water: 1.3 gal | 5 l  
20.4" x 20.8"

LINERS

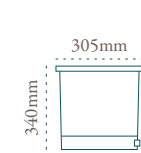

30 CM

round  
soil: 3.6 gal | 14 l  
water: 0.8 gal | 3 l  
13.8" x 12"

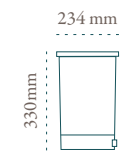

23 CM

round  
soil: 4.27 gal | 16.17 l  
water: 0.92 gal | 3.51 l  
12.9" x 9.2"

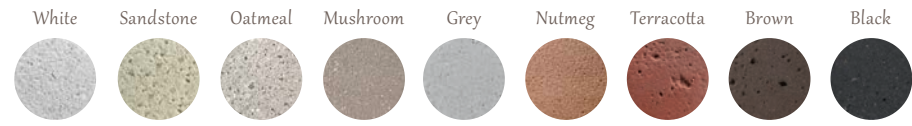

# "Self-Watering" Liners

All Indigenus planters come with a liner for planting. The drawings below each range preceding this page show the sizes and capacities. The liners have been designed to house plants in proportion to the planter size.

They contain a water reservoir at the base which uses the process of "capillary action", a type of wicking process, to feed water upwards to the roots over time. Water levels in the reservoir can be topped up directly with a watering can into a receptacle on the liner, and a gauge will indicate when the reservoir is full.



## Large | STE14S

All Stone  
weight: 85kg (187lb)  
inch: 55.1" x 34.6" x 19.5"

### Large Liner

## Medium | STE10S

All Stone  
weight: 45kg (99lb)  
inch: 39.3" x 25" x 14.1"

### Medium Liner

## Small | STE06S

All Stone  
weight: 15kg (33lb)  
inch: 24" x 15.4" x 8.7"

### Small Liner

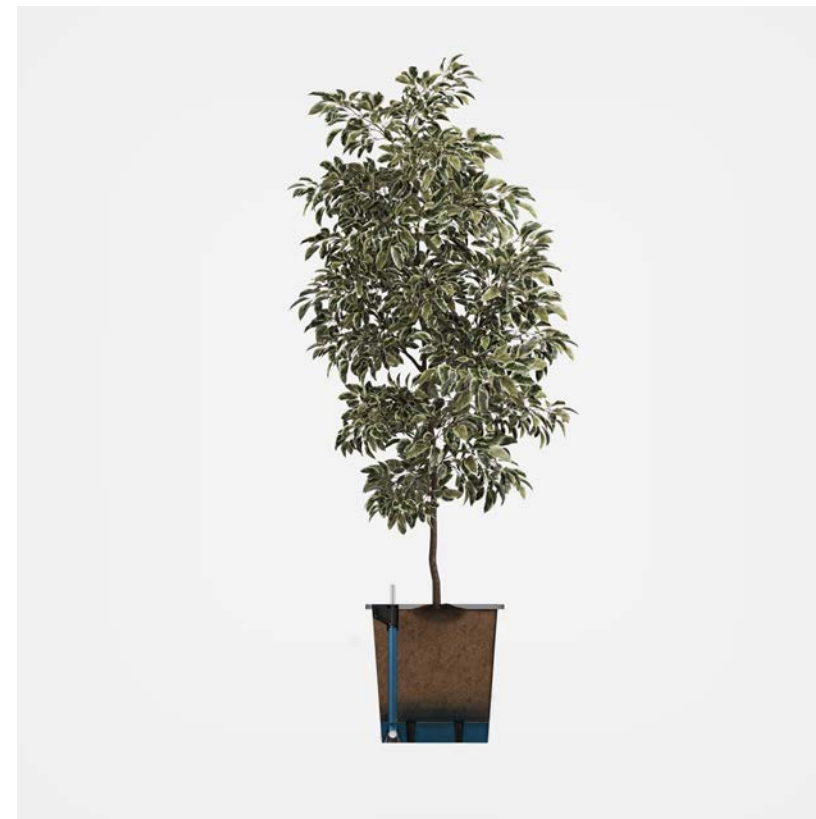

## LINERS

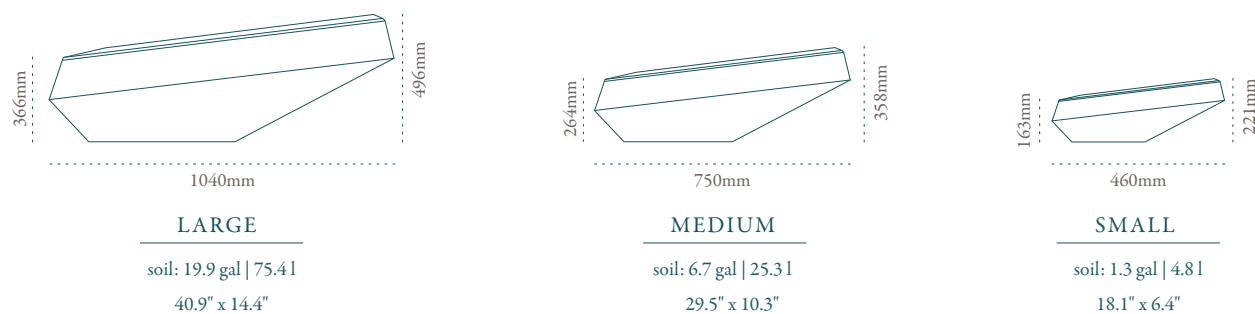

When outdoors in the rain, a small plug must be removed, and the reservoir acts as a drip tray containing the first rains, but it will overflow if it becomes full due to heavy rainfall. The rainwater left in the reservoir will then water the plant until it is depleted and needs refilling.

Always use the liner in conjunction with the planter, as the planters have not been designed to withstand the ground pressure of filling the entire planter directly with soil.



## Some of our Projects

Raffles Sentosa - Singapore  
 Jumeirah Al Naseem – Dubai  
 Movenpick Media City – Dubai  
 The Taj Exotica on the Palm – Dubai  
 Le Royal Meridien – Dubai  
 Shebara Island Red Sea Resort - Saudi Arabia  
 Hilton Yas Island – Abu Dhabi  
 Four Seasons Resort - Maui  
 Westin Resort and Spa– Maui  
 Hilton La Vacances – Honolulu  
 One and Only Le St Geran – Mauritius  
 Hilton Mango House – Seychelles  
 Standard Bank – Johannesburg  
 Discovery – Johannesburg  
 Amazon – Cape Town  
 Investec – Johannesburg, Cape Town  
 Radisson Collection – Cape Town  
 Fairmont Cape Grace – Cape Town  
 The Bay Hotel – Cape Town  
 Tommy Bahama – Seattle  
 Starbucks – Seattle  
 Sheraton Hotel and Marina – San Diego  
 Ritz Carlton – St Thomas, Sarasota, Paradise Valley, Santa Barbara  
 Virgin Hotels Nashville - Tennessee  
 Marriott World Centre - Florida  
 JW Marriott Bonnet Creek Resort & Spa – Florida  
 Payment Sense – London  
 Singita Kwitonda Lodge – Rwanda





INDIGENUS

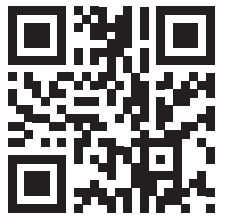

[info@indigenus.co.za](mailto:info@indigenus.co.za)

Visit [www.indigenus.co.za](http://www.indigenus.co.za) to find your nearest distributor

Photography by:  
Mark Williams (pgs cover, 14, 16, 20, 21, 22, 26, 28, 32, 34, 35, 38, 40, 42, 44, 46, 48, 49, 52, 55, 56, 57, 58, 62, 63)  
House of Zaan (pgs 4, 6, 8, 9, 15, 17, 23, 41, 47, 53, 60, 61, 80)  
Pete Maltbie (pgs 2, 62)